

# // SCHRAUBENZUGSMOMENTE UND AXIALE ROHRHALTEKRÄFTE // SCREW TIGHTENING TORQUE AND AXIAL PIPE SHEARING FORCES

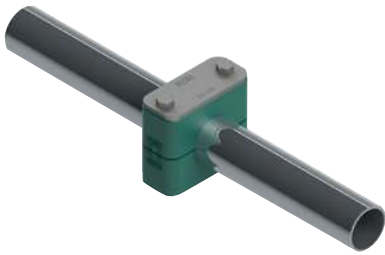

Die angegebenen Schraubenanzugsmomente und axialen Rohthaltekräfte beziehen sich auf Montage mit Anschweißplatten, Deckplatten und Außensechskantschrauben nach ISO 4014/4017 (DIN 931/933). Die axiale Rohthaltekraft (gemäß DIN 3015 Teil 10) ist ein Mittelwert, ermittelt aus drei Versuchen bei 23°C mit einem Stahlrohr nach DIN 2448 aus St 37, bei dem Haftreibung vorausgesetzt wird. Bei Belastung der RSB-Schelle in axialer Rohrrichtung mit der angegebenen Prüfkraft (F) gleitet das Rohr in der Schelle nicht.

The indicated screw tightening torque and axial pipe shearing forces refer to the assembly with weld plates, cover plates and hexagon head bolts according to ISO 4014/4017 (DIN 931/933). The axial pipe shearing force (according to DIN 3015, part 10) is an average value, determined by three tests made with a steel pipe according to DIN 2448 of St 37, for which static friction is presupposed (temperature during tests: 23°C). When loading the RSB clamp with the indicated test force (F) in axial pipe direction, the pipe does not slide in the clamp.

Leichte Baureihe (DIN 3015, Teil 1) / Light series (DIN 3015, part 1)

GRÖSSE SIZE	Befestigungs- schraube Fixing screw ISO 4014/4017 (DIN 931/933)	Polypropylen / Polypropylene		Polyamid / Polyamide		Aluminium / Aluminium	
		Schraubenanzugs- moment (Nm) Screw tightening torque (Nm)	Rohrhaltekraft F (kN) Pipe shearing force F (kN)	Schraubenanzugs- moment (Nm) Screw tightening torque (Nm)	Rohrhaltekraft F (kN) Pipe shearing force F (kN)	Schraubenanzugs- moment (Nm) Screw tightening torque (Nm)	Rohrhaltekraft F (kN) Pipe shearing force F (kN)
0	M 6	8	0,6	10	0,6		
1		8	1,1	10	0,7	12	4,2
2		8	1,2	10	0,8	12	4,3
3		8	1,4	10	1,6	12	4,8
4		8	1,5	10	1,7	12	5,0
5		8	1,9	10	2,0	12	7,3
6		8	2,0	10	2,5	12	8,9

Schwere Baureihe (DIN 3015, Teil 2) / Heavy series (DIN 3015, part 2)

GRÖSSE SIZE	Befestigungs- schraube Fixing screw ISO 4014/4017 (DIN 931/933)	Polypropylen / Polypropylene		Polyamid / Polyamide		Aluminium / Aluminium	
		Schraubenanzugs- moment (Nm) Screw tightening torque (Nm)	Rohrhaltekraft F (kN) Pipe shearing force F (kN)	Schraubenanzugs- moment (Nm) Screw tightening torque (Nm)	Rohrhaltekraft F (kN) Pipe shearing force F (kN)	Schraubenanzugs- moment (Nm) Screw tightening torque (Nm)	Rohrhaltekraft F (kN) Pipe shearing force F (kN)
1	M 10	12	1,6	20	4,2	30	12,1
2		12	2,9	20	4,5	30	15,1
3		15	3,3	25	5,1	35	15,5
4	M 12	30	8,2	40	9,3	55	29,4
5	M 16	45	11,0	55	15,8	120	34,8
6	M 20	80	14,0	150	21,0	220	50,0
7	M 24	110	28,0	200	32,0	250	70,6
8	M 30	180	40,0	350	48,0	500	84,5
9		200	119,0	370	125,0	500	181,5
10		270	168,0	450	180,0	600	244,5

Doppel-Baureihe (DIN 3015, Teil 3) / Double series (DIN 3015, part 3)

GRÖSSE SIZE	Befestigungs- schraube Fixing screw ISO 4014/4017 (DIN 931/933)	Polypropylen / Polypropylene		Polyamid / Polyamide	
		Schraubenanzugs- moment (Nm) Screw tightening torque (Nm)	Rohrhaltekraft F (kN) Pipe shearing force F (kN)	Schraubenanzugs- moment (Nm) Screw tightening torque (Nm)	Rohrhaltekraft F (kN) Pipe shearing force F (kN)
1	M 6	5	0,9	6	0,9
2	M 8	12	2,1	12	2,2
3		12	1,9	12	2,0
4		12	2,7	12	2,9
5		8	1,7	8	2,5

## // EMPFOHLENER SCHELLENABSTAND

## // RECOMMENDED CLAMP PITCH

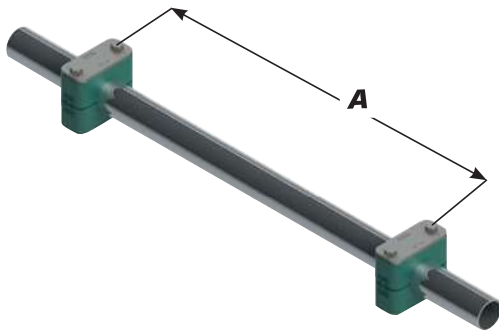

Die den entsprechenden Rohraußendurchmessern zugeordneten Schellenabstände sind Richtwerte für statische Belastung.

The clamp pitches assigned to the respective outside pipe diameters are standard values for static load.

Rohraußendurchmesser (mm) Outside pipe diameter (mm)	Schellenabstand A (m) Clamp pitch A (m)
6,0 - 12,7	1,0
12,7 - 22,0	1,2
22,0 - 32,0	1,5
32,0 - 38,0	2,0
38,0 - 57,0	2,7
57,0 - 75,0	3,0
75,0 - 76,1	3,5
76,1 - 88,9	3,7
88,9 - 102,0	4,0
102,0 - 114,0	4,5
114,0 - 168,0	5,0
168,0 - 219,0	6,0
219,0 - 324,0	6,7
324,0 - 356,0	7,0
356,0 - 406,0	7,5

## // ROHRBOGENMONTAGE

## // PIPE BEND ASSEMBLY



Rohrbögen sind unmittelbar vor und hinter dem Bogen mit RSB-Rohrschellen zu befestigen.

Pipe bends must be fixed with RSB-pipe clamps immediately in front of and behind the bend.